

Množstvo **Popis**

1

MAGNA1 80-80 F

Poznámka: Obrázok produktu sa môže líšiť od skutočného produktu

Objednacie č.: [99221411](#)

The Grundfos MAGNA1 circulator pump is the simple option for a job well done.

With its high energy efficiency the product lives up to the EuP 2015 regulations ensuring substantial savings on electricity, and with its intuitive, user-friendly interface and maintenance-free design, MAGNA1 is the ideal circulator pump for basic performance needs in applications where basic system control and monitoring are desired.

With this range of circulator pumps, everything from setup to basic control and monitoring are made easy. The pump is maintenance-free due to the canned-rotor type design.

MAGNA1 offers the possibility of monitoring the pump via the fault relay output. The digital start/stop input remotely controls the pump.

The pump communicates wirelessly with the Grundfos GO Remote app.

MAGNA1 can work as main pump in both heating and cooling applications, including:

- Mixing loops
- Heating surfaces
- Air-conditioning surfaces
- Ground-source heat pump systems
- Smaller chiller applications.

MAGNA1 is a single-phase pump and characterised by having the controller and operating panel integrated in the control box.

The pump housing is available in both cast-iron and stainless-steel versions.

The composite rotor can is carbon-fibre reinforced, the bearing plate and rotor cladding are made of stainless steel and the stator housing is made of aluminium.

The power electronics are air-cooled.

The pump incorporates a 4-pole synchronous, permanent-magnet motor (PM motor). This motor type is characterised by higher efficiency than a conventional asynchronous squirrel-cage motor. The pump speed is controlled by an integrated frequency converter.

99221411 MAGNA1 80-80 F

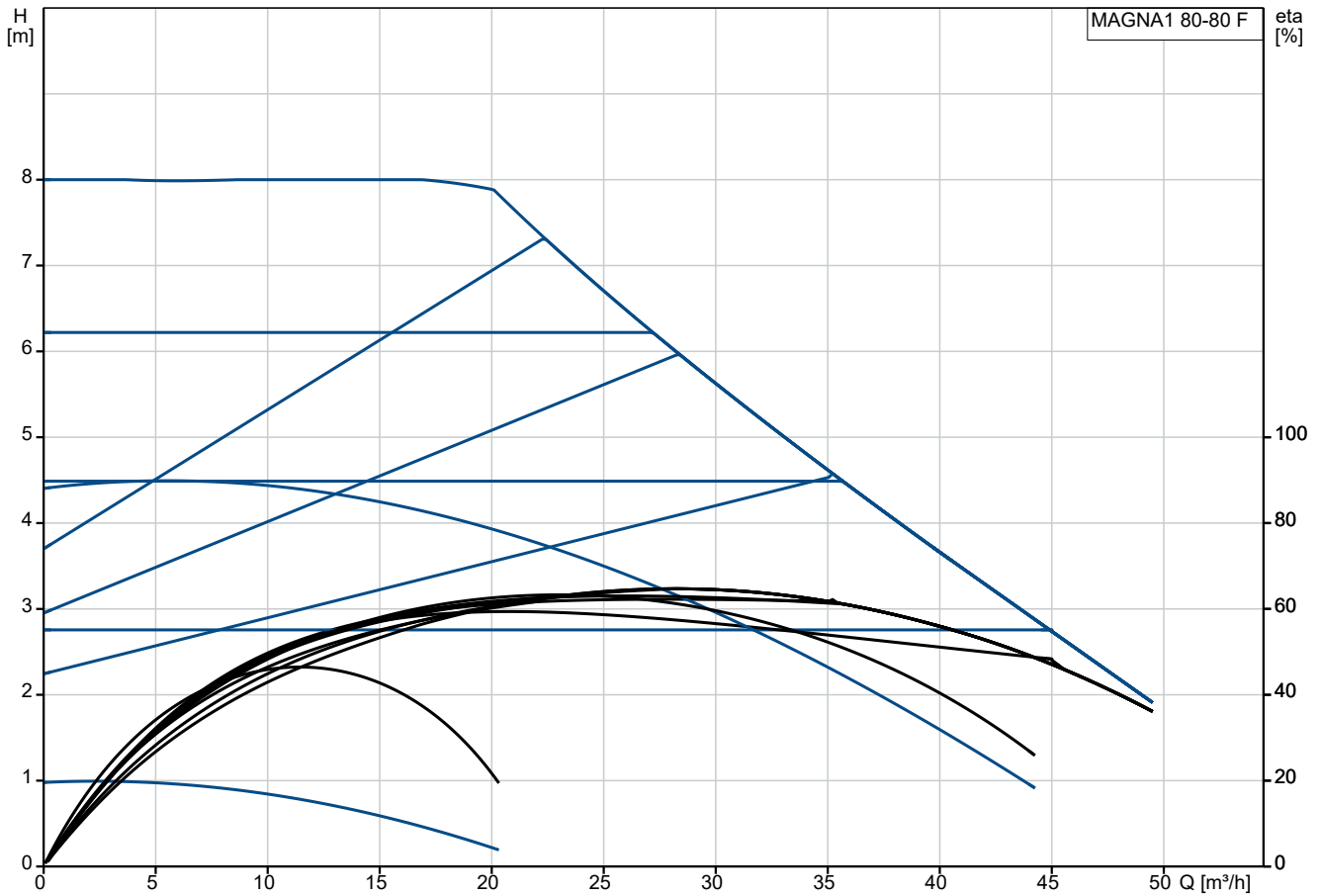

Čerpaná kvapalina = Voda
 Teplota kvapaliny počas prevádzky = 60 °C
 Hustota = 983.2 kg/m³

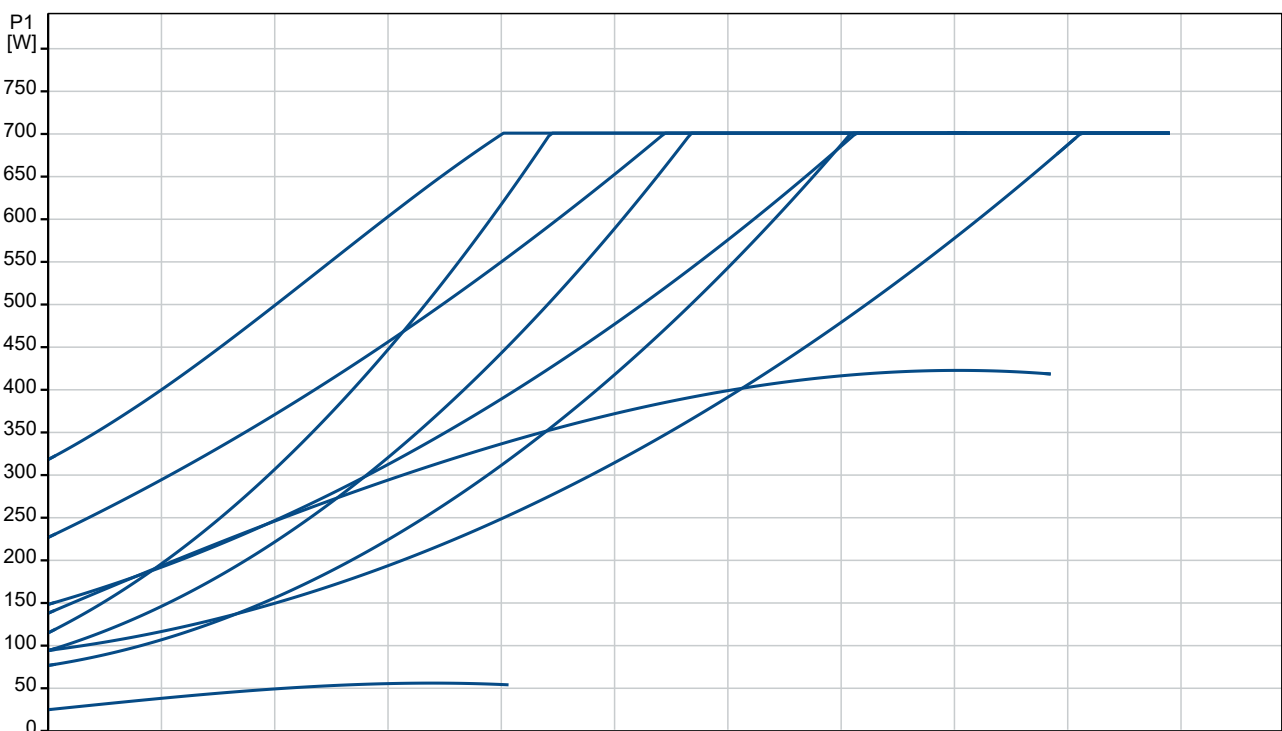

Popis	Hodnota
Všeobecné informácie:	
Názov produktu:	MAGNA1 80-80 F
Objednacie číslo:	99221411
Číslo EAN:	5712608943836
Cena:	EUR 3466
Techn.:	
Max. dopravná výška:	80 dm
Trieda TF:	110
Approvals:	CE,VDE,EAC,MOROCCO,UKCA,TSERCM,UkrSEPRO
Model:	C
Materiály:	
Teleso čerpadla:	Šedá liatina
Teleso čerpadla:	EN-GJL-250
Teleso čerpadla:	ASTM A48-250B
Obežné koleso:	PES 30%GF
Inštalácia:	
Rozsah teploty okolia:	0 .. 40 °C
Maximálny prevádzkový tlak:	10 bar
Štandardná príruha:	DIN
Potrubná prípojka:	DN 80
Hodnota tlaku:	PN 10
Vzdialenosť sac.-výtl.:	360 mm
Kvapalina:	
Čerpaná kvapalina:	Voda
Rozsah teploty kvapaliny:	-10 .. 110 °C
Vybraná teplota kvapaliny:	60 °C
Hustota:	983.2 kg/m ³
Elektrické údaje:	
Príkion - P1:	26.32 .. 715 W
f:	50 / 60 Hz
Menovité napätie:	1 x 230 V
I MAX:	0.28 .. 3.14 A
Krytie IP:	X4D
Izolácia:	F
Iné:	
Energia (EEI):	0.20
Čistá hmotnosť:	28.4 kg
Hrubá hmotnosť:	31.2 kg
Prepravné množstvo:	0.071 m ³
Fínčina:	4615221
Krajina pôvodu:	DE
Tarifná klasifikácia č.:	84137030
Environmental approvals:	CN ROHS,WEEE

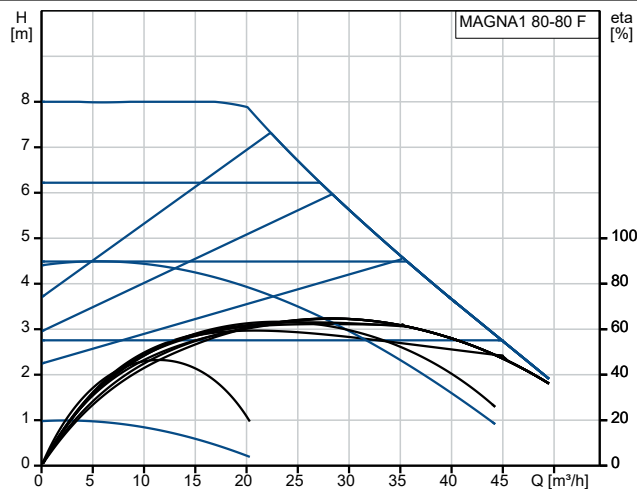

Čerpaná kvapalina = Voda
 Teplota kvapaliny počas prevádzky = 60 °C
 Hustota = 983.2 kg/m³

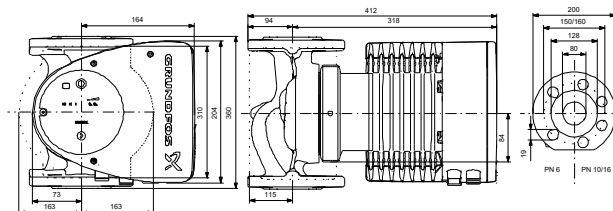
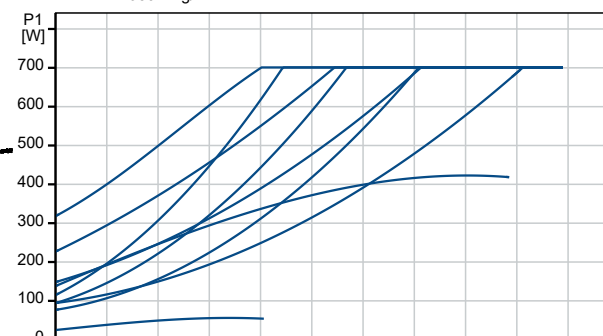

Example of mains-connected motor with mains switch, backup fuse and additional protection

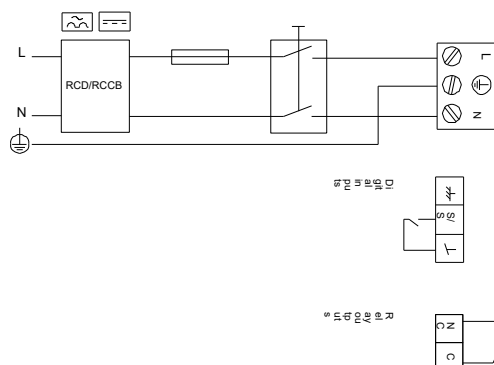

99221411 MAGNA1 80-80 F

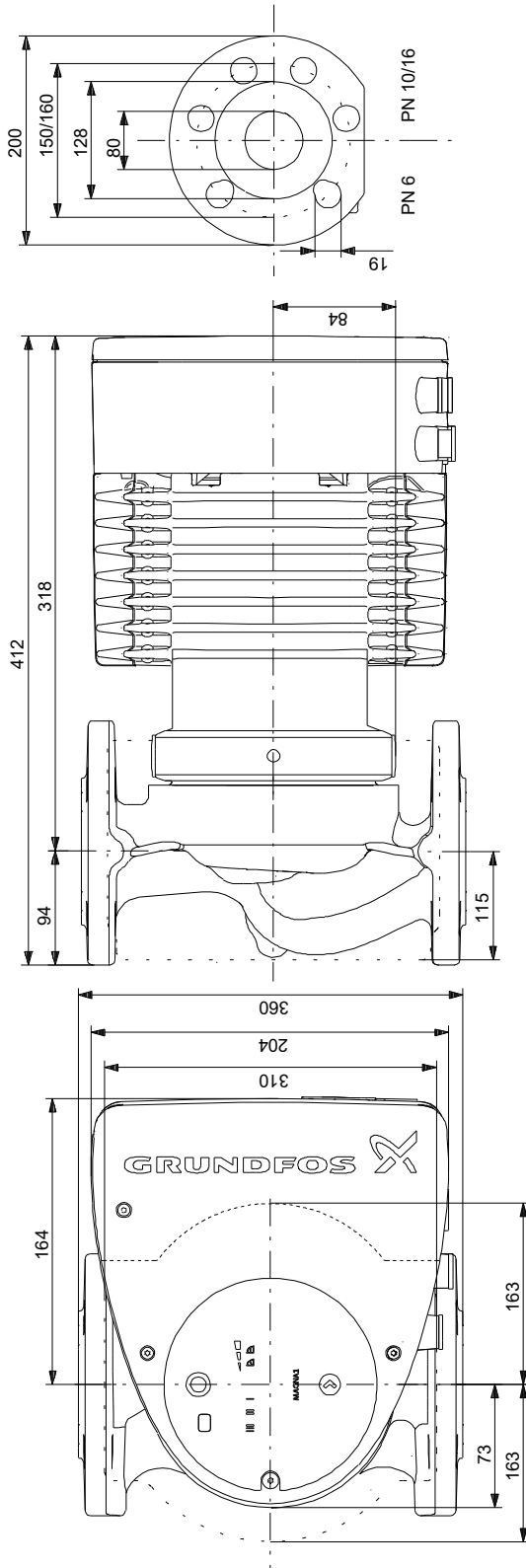

Upozornenie! Všetky jednotky musia byť v [mm], pokiaľ nie je uvedené inak.
 Poznámka: Tento zjednodušený rozmerový náčrtok nezobrazuje všetky detaily.

99221411 MAGNA1 80-80 F

Example of mains-connected motor
 with mains switch, backup fuse and additional protection

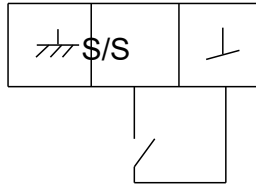
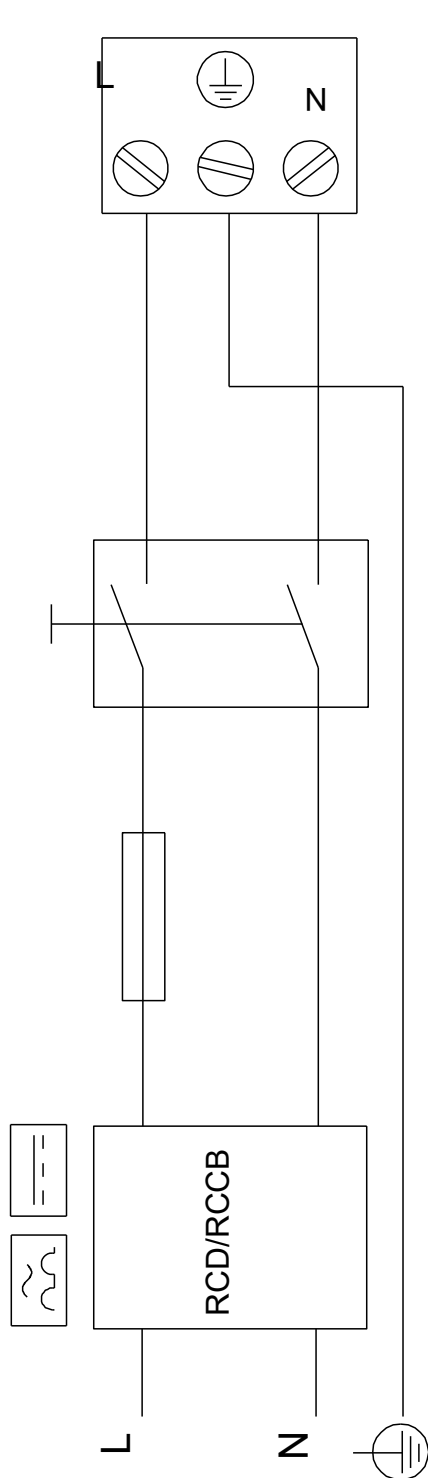

Digital inputs

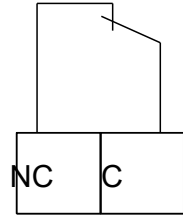

Relay outputs

Upozornenie! Všetky jednotky sú v [mm], pokiaľ nie je uvedené inak!



Názov spoločnosti: VPK, s.r.o.
Vytvoril: Martin Baloga
Telefón: +421 944 258 730
Email: info@cerpacia-technika.sk
Dátum: 22.2.2023

Objednávacie údaje:

Pozícia	Vaša poz.	Názov produktu	Množstvo	Objednacie číslo	Celkom
		MAGNA1 80-80 F	1	99221411	Cena na požiadanie